

SAFETY IN SCAFFOLDING

INTRODUCTION

Scaffolding operation in construction work is considered as highly technical operations with serious hazard potential.

Unless correct steps are taken, a loss prevention programme at job site, it may end up with serious trouble with loss in job schedule, workmen, company image and property.

Hence, to perform the job safely, knowledge on scaffolding, safe erection and maintenance & inspection are essential.

SCAFFOLD TERMINOLOGIES

Anchorage : Safe points of anchorage for lifelines or lanyards, which are part of a personal fall arrest system, including fixed, substantial structural members. Anchorage points shall be fixed and able to support a load of at least 2,300 kilograms (5,000 pounds).

Base Plate : A steel plate providing a flat bearing surface with a spigot or screwjack for distributing the load from posts (standards). It has an integral spigot and fixing holes for use with sills.

Bearer (Transom) : A horizontal transverse scaffold member, that may support platform units, and which is supported by at least two runners (ledgers) or connected directly to at least two posts (standards).

Board Bearer (Intermediate Transom) : A horizontal transverse scaffold tube upon which the scaffold platform partially rests. Board bearers are supported by runners (ledgers) and are not installed near a transverse line of posts (standards).

Safety Belt : A strap with means both for securing it about the waist and for attaching it (with a lanyard) to a lifeline or anchorage. Used to provide personnel positioning limits against a fall (i.e., keep wearer away from edge of a roof). *Body belts shall not be used as part of a personal fall arrest system.*

Box Tie : An assembly of tubes and couplers forming a frame around a column or other part of a building to provide an anchor point for scaffold tie tubes. Also known as a column box tie.

Brace : A rigid connection of scaffold tubing that holds one scaffold member in a fixed position with respect to another member to give the scaffold rigidity.

Cross Bracing : Two diagonal braces joined at their center to form an “X.” Also called “X” bracing or cross braces.

Diagonal Brace : A scaffold tube placed diagonally with respect to the vertical and horizontal members of a scaffold and fixed to them to give the scaffold stability.

Longitudinal (Facade or Sway) Bracing : Diagonal braces installed in the plane of the longer dimension (length) of the scaffold.

Plan Bracing : Diagonal braces installed in a horizontal plane, particularly used in mobile and tower scaffolds.

Transverse (Sectional or Ledger) Bracing : Diagonal braces installed in the plane of the shorter dimension (width) of the scaffold.

Zig-Zag (Dog-leg) Bracing : Diagonal braces placed end-to-end and that alternate back and forth.

Caster (Castor) : A pivoting wheel, containing a wheel lock, which is attached to a vertical post (standard) of a mobile scaffold to allow for manual movement of the scaffold.

Coupler (Fitting, Clamp) : A component or device used to fix scaffold tubes together. Types of couplers include:

Adjustable (Swivel) Coupler : A device used for connecting two tubes together at an angle other than 90°.

Bearer (Single or Putlog) Coupler : A device used for fixing a bearer (transom or putlog) to a runner (ledger), or to connect a tube used only as a guardrail to a post (standard).

Check (Safety) Coupler : A Right-angle coupler added to a loaded joint on an underhung scaffold to give supplementary security against slip to the coupler carrying the load.

End-to-End (Sleeve) Coupler : A device used for externally joining two scaffold tubes co-axially end to end. The steel divider is located centrally to ensure equal insertion of each tube.

Girder Coupler : A device used for connecting a scaffold tube to a steel wideflange beam (I-beam). Girder couplers shall only be used in pairs, one on each opposite flange.

Right-Angle (Double, 90 Degree, Load Bearing, or Standard) Coupler :

A load bearing coupler used for connecting two tubes together at right angles. It is a critical component in the scaffold structure and must resist both slip and distortion.

Fabricated Scaffold Plank, Deck, or Platform : A scaffold platform unit equipped with end hooks that engage the scaffold bearer (transom).

Full Body Harness : A design of straps that may be secured about an individual in a manner to distribute the fall arrest forces over the thighs, pelvis, waist, chest and shoulders, with means for attaching it to other components of a personal fall arrest system.

Guardrail System : A barrier consisting of toprails, midrails, toeboards, and supporting uprights, erected to prevent workers from falling off an elevated work area and to prevent objects from falling onto workers below.

Top rail : The uppermost horizontal rail of a guardrail system.

Mid rail: A horizontal rail approximately midway between the toprail of a guardrail system and the platform.

Toe board : A barrier secured along the sides and the ends of a platform to guard against the falling of material, tools, and other objects.

Guys : Tension members (i.e., wire ropes) used between the scaffold and the ground, building, or structure to enhance the scaffold's lateral stability.

Hanger Tube : Vertical tube similar to and serving the same load-carrying purpose as posts (standards), except that hanger tubes are hung from an existing structure and loaded in tension.

Joint Pin (Expanding Spigot) : An expanding fitting placed in the bore of a scaffold post (standard) to connect one post to another coaxially. This device is used to connect posts (standards) in tube and coupler scaffolds vertically and handles compression, but not tension, loads.

Ladder : A device used for climbing vertically between levels, including:

Extension Ladder : A portable ladder that cannot support itself but can be adjusted in length. It consists of two sections that are arranged to permit length adjustment.

Straight Ladder : A portable ladder that consists of one section that determines its overall length. It cannot support itself or be adjusted in length.

Lanyard : A flexible line with a positive means to lock end connections closed (i.e., locking type snap hooks or carabineers with a self-closing, self-locking keeper) that is used to secure the wearer of a full body harness to a lifeline or a point of anchorage.

Shock-absorbing Lanyard : A specially designed lanyard with a built-in shock absorber (to allow dissipation of energy) that elongates during a fall so that fall arresting forces are significantly reduced (by 65 – 80%) when compared to a traditional webbing or rope lanyard. A shock-absorbing lanyard limits the maximum arresting force on the individual to less than 8,000 Newtons (1,800 pounds).

Lifeline : A component that consists of a flexible line that connects to an anchorage at one end to hang vertically (vertical lifeline), or that connects to anchorages at both ends to stretch horizontally (horizontal lifeline), and which serves as a method to connect other components of a personal fall arrest system to the anchorage. Lifelines are also called static lines, drop lines, safety lines, rat lines, scare lines, etc.

Lift : The assembly of runners (ledgers) and bearers (transoms) forming a horizontal level of a scaffold. A lift is similar to a floor in a building.

Base Lift : A lift erected near to the ground consisting of the first set of runners (ledgers) and bearers (transoms). Also known as “foot lift”, “foot tie”, and “kicker lift.”

Lift Head Room : The clear distance between a platform and the tubular assembly of the lift above.

Lift Height : The vertical distance between two lifts and is similar to a story in a building.

Load Rating : Live load for scaffold design and maximum intended loading shall be per the following categories:

Light-duty : Scaffold designed and constructed to carry the weight of workmen only, with no material storage other than the weight of tools. Commonly used for inspection, painting, access and light cleaning. Uniformly distributed maximum intended load is 120 kg/m² (1.2 kN/m²).

Medium-duty: Scaffold designed and constructed to carry the weight of light materials, tools and workmen. Scaffolds used for abrasive blast cleaning (“sandblasting”) shall be classified Medium-duty if there is potential for buildup of abrasive on the platforms (all platforms are not continuously cleaned of abrasive). Uniformly distributed maximum intended load is 240 kg/m² (2.4 kN/m²).

Special-duty: Scaffold specially designed and constructed to carry maximum intended loads *greater than* 240 kg/m² (2.4 kN/m²) (50 psf), such as masonry work, piping or equipment, and is classified as a Special Scaffold.

Outrigger : The structural members of a supported scaffold used to increase the base width of a scaffold in order to provide support for and increased stability of the scaffold.

Safe Working Load (SWL) : The manufacturer’s specified maximum load to be applied to a scaffold component.

Scaffold : A temporary elevated platform (supported or underhung) and its

supporting components (including ties) used for supporting workmen, materials, or both. Types of scaffolds include:

Base-Supported Scaffold : A scaffold with posts (standards) supported at their base (not under hung).

Birdcage Scaffold: A scaffold with more than two lines of posts (standards) or hanger tubes (if under hung) across the width of the scaffold.

Bracket (Tank Builder's) Scaffold : A scaffold supported by bracket straps welded to the tank wall. Upright brackets are hooked to the straps.

Fabricated Tubular Frame Scaffold : A scaffold consisting of platform(s) supported on fabricated end frames with integral posts, horizontal bearers, and intermediate members.

Mobile Scaffold : A rigid scaffold assembly supported by casters that can be manually moved horizontally.

System Scaffold : A scaffold consisting of posts (standards) with fixed connection points that accept runners (ledgers), bearers (transoms), and braces that can be interconnected at predetermined levels.

Tower Scaffold : A supported scaffold consisting of *only* four (4) posts (standards) connected together longitudinally with runners (ledgers) and bearers (transoms) at right angles to each other, forming a square or rectangular tower. A tower scaffold may be constructed of tube and coupler, fabricated tubular frame, or system scaffolding.

Tube and Coupler Scaffold : A scaffold constructed of steel tubing that serves as posts (standards), runners (ledgers), bearers (transoms), braces, and ties; a base supporting the posts; and specially designed scaffold couplers that serve to connect the various members.

Underhung (Slung or Suspended) Scaffold : A scaffold that is suspended by fixed length wire ropes (cables) or rigidly attached by scaffold tubes and load bearing couplers to an overhead structure directly above (not outrigger beams), and having a work platform that cannot be raised or lowered.

Bay :The space between the centerlines of adjacent posts (standards) along the face of a scaffold.

Bay Length :The horizontal, longitudinal distance between centers of two adjacent posts (standards).

Height :The vertical distance between the scaffold base and the topmost assembly of runners (ledgers) and bearers (transoms).

Length : The horizontal distance along the runners (ledgers) between the scaffold's extreme longitudinal posts (standards); sometimes designated by the number of

bays.

Longitudinal : The long direction of the scaffold, usually parallel to the scaffold's planks.

Transverse : The short direction of the scaffold, usually perpendicular to the scaffold's planks.

Sole Board or Sole Plate : A timber spreader used to distribute the load from a base plate to the ground.

Tie Scaffold components installed to provide an anchor point for a scaffold to a building or structure, including tie tubes attached to the scaffold. Used to provide lateral stability to the scaffold.

Scaffold Materials :

- a). The components used to assemble scaffolds shall be inspected before each use and shall conform to requirements of this section regarding materials, strength, dimensions, etc.
- b). Scaffold components manufactured by different manufacturers shall not be intermixed unless the components are compatible (fit together without mechanical force) and the scaffold's structural integrity is maintained. Scaffold components manufactured by different manufacturers shall not be modified in order to intermix them.
- c). Scaffold components shall be free from detrimental corrosion.
- d). Any scaffold component that is obviously damaged, excessively corroded, defective, or does not meet the applicable codes and standards shall be marked and be immediately destroyed and shall not be re-used on the project site. However, if possible, defective sections of planks or tubing may be cut off. In this case, the plank or tubing may be reused.
- e). Scaffold components made of dissimilar metals shall not be used together because of the potential for galvanic corrosion.
- f). Scaffold components shall not be exposed to acids or other corrosive substances, unless adequate precautions have been taken to protect the scaffold from damage.
- g). Where a built-in ladder is part of a scaffold system, it shall conform to the requirements for ladders (IS: 3696, Pt-II).
- h). Scaffold components shall be properly stored to prevent damage.

Scaffold Foundation

- a). Foundations shall be sound, rigid, and capable of carrying the scaffold self-weight plus the maximum intended load without settling or displacement.
- b). Unstable objects such as barrels, boxes, loose brick or concrete blocks shall not be used to support scaffolds, planks, or timber sills.
- c). A sound base is essential. Therefore, the ground or floor on which a scaffold

- stands shall be carefully examined for its load-bearing capacity.
- d) Sand or made-up ground (fill) may need compacting to ensure there are no cavities. Such bases as floors, roofs, etc., may need shoring from underneath.
 - e). Timber sills (sole boards) at least 225 mm (9 inches) wide by 38 millimeters (1-1/2 inches) thick shall be used to spread the load on sand, made up ground, asphalt pavement, wooden floors, and other soft or slippery surfaces.
 - f) The ground beneath sills shall be level and compact. A sill shall extend under at least two posts (standards), unless not feasible because of uneven or sloping ground.
 - g). All scaffold posts (standards) shall be pitched on steel base plates at least 150 millimeters (6 inches) by 150 millimeters (6 inches) and 6 millimeters (1/4-inch) thick.
 - h) For Special Scaffolds, the base plate shall be designed to support the maximum scaffold post (standard) load. Timber sills shall be used where base plates may be exposed to corrosive materials.
 - i). Screw jacks shall be used to compensate for variations in ground level.
Screw jacks shall not be adjusted to more than two-thirds of the total length of the threaded section.
 - j) Screw jacks shall be used and loaded in accordance with the manufacturer's specifications.
 - k). Front-end loaders, forklifts, or pieces of equipment shall not be used to support scaffolds.
 - l). Scaffolds shall not be hung from or supported by guardrails or handrails.
 - m). A crane or other lifting device shall not lift any scaffold, unless it's a Special Scaffold specifically designed for lifting and the scaffold plan was reviewed in accordance with the requirements of the standard practices.

Foundations

- Scaffolding foundations must be adequate to carry the whole weight of the scaffold.
- Steel base plates must be used under all standards.
- When scaffolds are supported on the ground, suitable sole plates must be used to spread the load.
- The sole plates should preferably be long enough to support at least two standards.
- Timber sole plates must be not less than 200 x 38 x 500 mm long.
- Bricks, blocks and similar loose material are unsuitable as they are liable to fall over or split, and are easily driven into the ground.
- Where the foundation is levelled concrete of adequate thickness or of a

similar hard surface, the sole plate may be omitted, but steel base plates must be provided at the bottom of all standards.

Guardrails and Midrails and Toe board

- Guardrails, including midrails, must be provided on the exposed sides and ends of all working platforms more than 3 m in height. The height to the top of the guardrail must be not less than 0.95
- A midrail is required on a working platform which should be placed exactly half of the height of the top rail
- Each rail, when secured to upright members, must be capable of sustaining without failure or undue deflection a force at any point of 70 kg .
- A toeboard of 150 mm minimum height should be provided for protection against fall of materials from the platform.

Screens/Nets

- When scaffold platform is above a public thoroughfare, to avoid falling of material , resulting in injury to passers-by, special precautions must be taken. Special protection may consist of:
- Screening with mesh opening not exceeding 50 mm , shall be provided to the working platforms to a height of at least 1 m.
- Catch screens shall be provided , where the horizontal distance from the scaffolding is more than half the vertical distance between the screen and the middle of the topmost working platform of the scaffold.
- Containment sheeting is to be provided to protect , the public from the construction works and to provide weather protection for construction workers working on or about the scaffolding.

PLATFORM DECKING

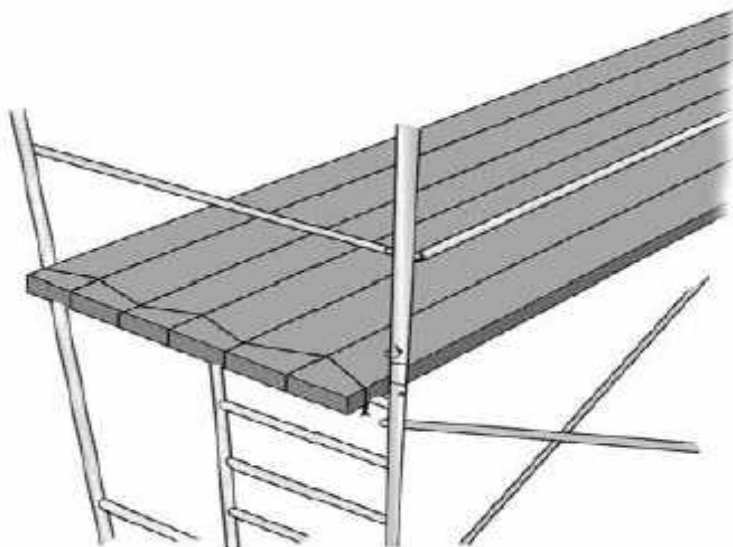

CROSS BRACING

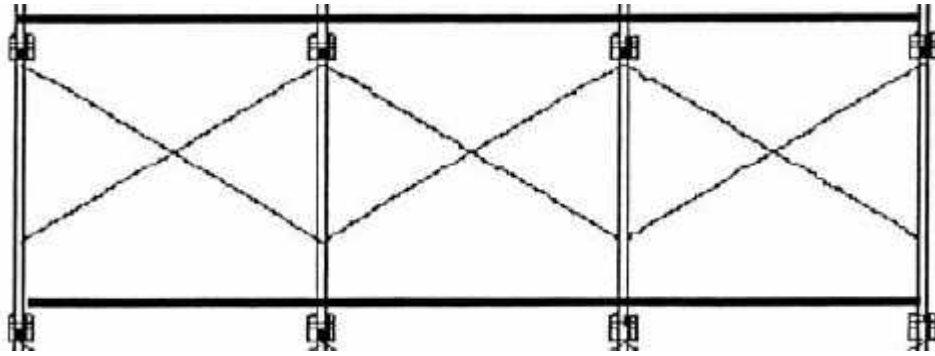

PLAN BRACING
DOGLEG BRACING

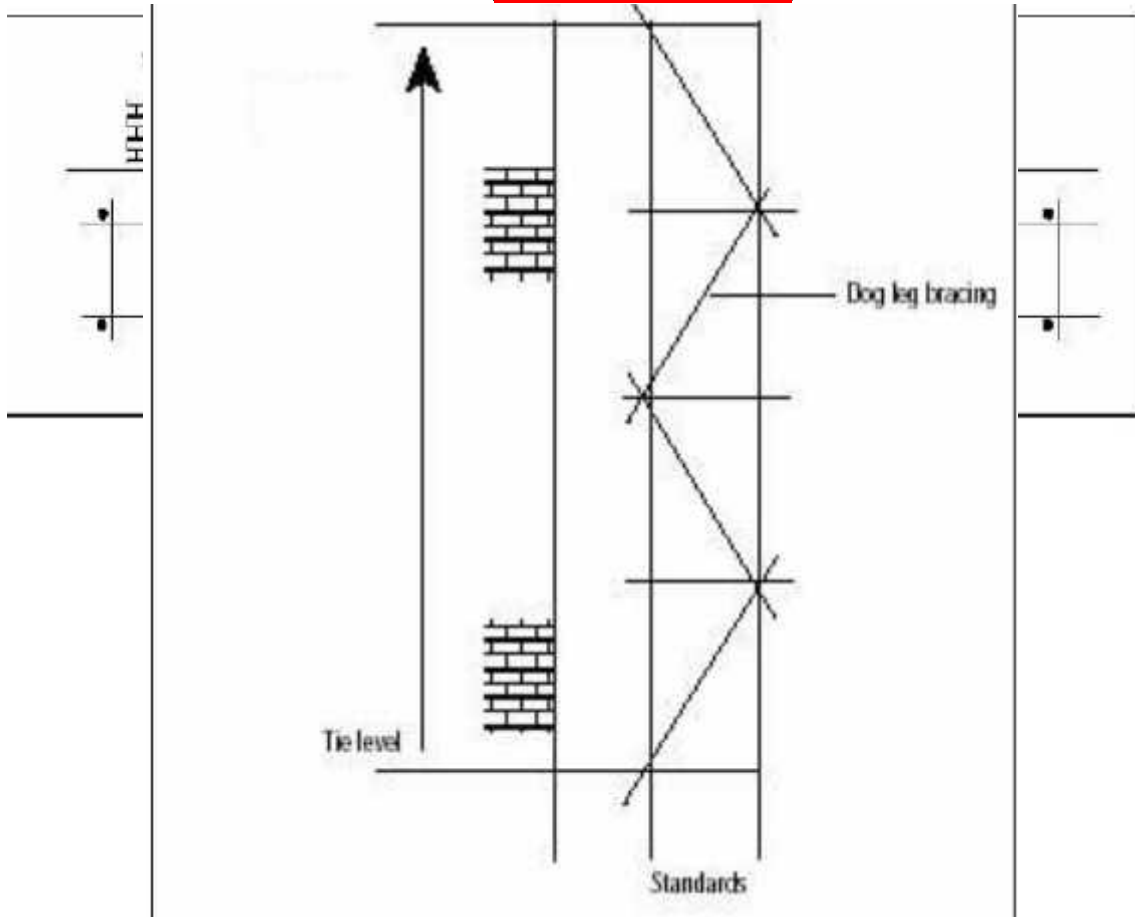

DIAGONAL BRACING

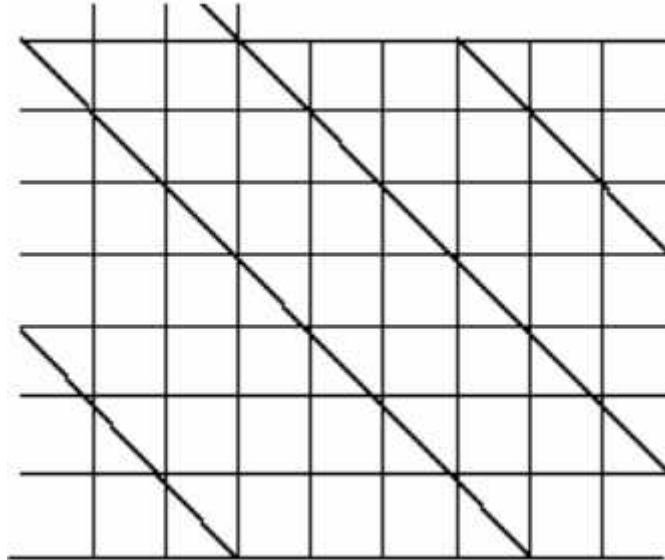

CLEARANCE FROM ELECTRICAL LINES

The required minimum safe distances to avoid electrocution from electrical lines is given below.

Voltage	Safe Clearance
upto 300 Volts	1.0 meter
300 - 750 Volts	2.0 meter
750-15, 000 Volts	3.0 meter
15, 001-250, 000 Volts	4.5 meter
Over 250, 000 Volts	6.0 meter

Hazard in scaffolding activities

Hazards on Scaffolding

- Fall of persons
- Fall of materials and articles
- Failure of the scaffold due to overloading
- Failure of the scaffold members during erection and dismantling
- Contact with energised power lines
- Environmental

Problem areas

- Erecting and dismantling scaffolds
- Climbing up and down scaffolds
- Planks sliding off or breaking
- Improper loading or overloading
- Platforms not fully planked or “decked”
- Platforms without guardrails
- Failure to install all required components such as base plates, connections, and braces
- Moving rolling scaffolds in the vicinity of overhead electrical wires

Training and information to employees

Before employees begin work, they must be informed by their employer of:

- Hazards employees may be exposed to while at work;
- Hazards employees may create which could harm other people;
- How to minimize the likelihood of these hazards becoming a source of harm to themselves and others;
- The location of safety equipment; and
- Emergency procedures.

Assigning Personnel

- Responsible person should oversee the scaffold selection, erection, use, movement, alteration, dismantling, maintenance and inspection.
- Only trained and experienced personnel should be assigned the work of scaffolding.

Training

- Employees should receive instruction on the particular types of scaffolds that they are to use.
- Training should focus on proper erection, handling, use, inspection, removal and care of the scaffolds.
- Training must include the installation of fall protection, particularly guardrails, and the proper selection, use and care of fall arrest equipment.
- The competent person(s) should receive additional training regarding the selection of scaffolds, recognition of site conditions, scaffold hazard recognition, protection of exposed personnel and the public, repair and replacement options, and requirements of standards.
- Site management personnel should also be familiar with correct scaffolding procedures so they can better determine needs and identify deficiencies.

Fall Protection

- Guardrails must be installed on all scaffold platforms in accordance with required standards and at least consist of top rails, mid-rails and toe boards (if more than 3 meter above the ground or floor).
- When it is necessary to remove guardrails (for example, to off-load materials), supervision must ensure that they are replaced quickly.
- Hard hats should be worn at all times to protect against falling objects.
- Mesh, screens, intermediate vertical members or solid panels should be used to safeguard employees and the public at lower levels.
- Ground-level safety can be further provided by erecting canopies; by prohibiting entry into the fall hazard area by policy, barricades and signs; and by the proper placement of materials, tools and equipment on scaffolding.
- Workers on suspended scaffolds must use a fall arrest system as protection against the failure of the scaffold or its components.
- Care must be taken to ensure that rope grabs are properly connected to lifelines so the cam will work correctly.
- Independent vertical lifelines (not scaffold suspension lines) of fiber rope should be used for each person working on the suspended scaffold.
- In the presence of flame or heat, wire rope lifelines should be used with lanyards containing shock absorbers.
- Vertical lifelines should extend from the anchorage point to the ground or a safe landing place above the ground.

GUIDELINES FOR PROPER ERECTION

- Supervision while erection of scaffolding shall be done by a person competent by skill, experience and training to ensure safe installation according to the manufacturer's specifications and other requirements.
- Knowledge of the voltage of energized power lines and increased awareness of location of energized power lines is essential . Safe clearance between scaffolds and power lines must be maintained . (i.e., minimum distance of 1 meter for insulated lines less than 300 volts; 3 meter for insulated lines 300 volts or more).
- Identify heat sources like steam pipes. Anticipate the presence of hazards before erecting scaffolds and keep a safe distance from them.
- Be sure that fall protection equipment is available before beginning erection and use it as needed.
- Have scaffolding material delivered as close to the erection site as possible to minimize the need for manual handling.
- Arrange components in the order of erection.
- Ensure the availability of material hoisting and rigging equipment to lift components to the erection point and eliminate the need to climb with components.
- Examine all scaffold components prior to erection. Return and tag "Do Not Use" or destroy defective components.
- Prohibit or restrict the intermixing of manufactured scaffold components, unless:
 - The components fit together properly, without force,
 - The use of dissimilar metals will not reduce strength, and
 - The design load capacities are maintained.
- All scaffold decks should be planked as fully as possible (beginning at the work surface face) with gaps between planks no more than 25 mm wide (to account for plank warp and wane).
- Platform units must not extend less than 150 mm over their supports unless they are cleated or contain hooks or other restraining devices.
- When platform units are abutted together or overlapped to make a long platform, each end should rest on a separate support or equivalent support.
- Wood preservatives, fire retardant finishes and slip-resistant finishes can be applied to platform units; however, no coating should obscure the top and bottom of wooden surfaces.
- If fire retardants are used, an engineer should ensure that the plank(s) will carry the required load since fire retardants can reduce the plank load capacity.
- Provide suitable access to and between scaffolds. Access can be provided by portable ladders; hook-on ladders; attachable ladders; stairway-type ladders; integral prefabricated scaffold rungs; direct passage from another scaffold, structure or personnel hoist; ramps; runways; or similar adequate means.
- Crossbraces and scaffold frames shall not be used for access scaffold platforms unless they are equipped with a built-in ladder specifically designed for such purpose.

GUIDELINES FOR USE

- Scaffolds and components are not loaded beyond their rated and maximum capacities.
- Movement of mobile scaffolds when employees are on them must be prohibited.
- Maintain a safe distance from energized power lines.
- Materials that could cause slipping and falls are to be removed.
- Protection of suspension ropes from contact with sources of heat (welding, cutting, etc.) and from acids and other corrosive substances.
- Scaffold usage during storms and high winds must be avoided.
- Debris and unnecessary materials from scaffold platforms should be removed.
- Usage of ladders and other devices to increase working heights on platforms should be avoided.

ALTERATION AND DISMANTLING

- Scaffolds are to be altered, moved and dismantled under the supervision of a competent person.
- Alteration and dismantling activities should be planned and performed with the same care as with erection.
- Tag any incomplete scaffold or damaged component out of service.

Maintenance and Storage

- Scaffolds to be maintained in good repair.
- Replacement components from the original manufacturer should be used.
- Intermixing scaffold components from different manufacturers should be avoided.
- Fabricated scaffolds should be repaired according to the manufacturer's specifications and guidance.
- Scaffolding parts should be stored in an organized manner in a dry and protected environment.
- All parts must be examined , cleaned, repaired or disposed off as per standards.

SCAFFOLDING CHECKLIST

SI No.	Points	Observations	
		Available	Not available
1.	Does each scaffold and scaffold component support (without failure) its own weight and at least 4 times the maximum intended load?		
2.	Are all working levels on scaffolds fully planked or decked between the front uprights and the guardrail supports?		
3.	Are scaffold platform spaces 25 mm or less between adjacent units and the uprights?		
4.	Are all scaffolding platforms at least 450 mm wide?		
5.	Is the distance between the front edge of the scaffold platform and the face of the work 350 mm or less, unless guardrail systems are put along the front edge, or personal fall arrest systems are used?		
6.	Does the end of each scaffold platform extend over the centerline of its support at least 150 mm unless cleated or otherwise restrained by hooks or equivalent means?		
7.	If the scaffold platform is 3 Meter or less in length, does the end of the scaffold platform extend 3.5 Meter or less over its support?		
8.	On scaffolds where platforms overlap to form a long platform, does the overlap occur over supports? Is the overlap at least 300 mm unless the platform is nailed together or otherwise restrained to prevent movement?		
9.	At points of a scaffold where the platform changes direction, is this procedure followed?		
10.	Are supported scaffolds with a height to base width ratio of more than 4 to 1 restrained from tipping by guying, tying, bracing, or equivalents?		
11.	Are supported scaffold poles, legs, posts, frames, and uprights placed on base plates and mudsills or other firm foundation?		
12.	Is footings level, sound, and rigid? Can they support the loaded scaffold without settling or displacement?		
13.	Are supported scaffold poles, legs, posts, frames, and uprights plum and braced to prevent swaying and displacement?		

14.	Are ladders, stairs, ramps, or walkways provided to access scaffold platforms more than 1000 mm above the point of access?		
15.	Do stairway-type ladders have slip-resistant treads on all steps and landings?		
16.	Do ramps and walkways 2000 mm or more above lower levels have guardrails?		
17.	Do employees have fall protection if integral prefabricated scaffold access frames with rungs less than 300 mm are used as work platforms?		
18.	During erecting and dismantling of supported scaffolds , does a competent person provide and evaluate safe means of access?		
19.	Are scaffolds and scaffold components loaded below their maximum intended loads or rated capacities (whichever is less)?		
20.	Does a competent person inspect scaffolds and scaffold components for visible defects before each work shift, and after any occurrence that could affect a scaffold's structural integrity?		
21.	Are parts of a scaffold that are damaged or weakened immediately repaired, replaced, braced, or removed from service until repaired?		
22.	Are proper clearances (as shown in Tables 1 and 2) between scaffolds and power lines always maintained?		
23.	Are scaffolds erected; moved, dismantled, or altered only under the supervision and direction of a competent person qualified in scaffold erection, moving, dismantling, or alteration?		
24.	If swinging loads are hoisted onto or near scaffolds, are tag lines or equivalent measures used to control the loads?		
25.	Is working on scaffolds during storms or high winds prohibited unless a competent person has determined that it is safe for workers to be on the scaffold and workers are protected by a personal fall arrest system or wind screens?		
26.	Is debris removed from platforms?		
27.	Are makeshift devices, such as boxes and barrels, prohibited on scaffold platforms for increasing the working level height?		
28.	Is it prohibited to use ladders on scaffolds to increase the working level height?		

